

## Chapter 21

# Some Aspects of the Balun Problem

(Adapted from *QST*, March 1983)

### Sec 21.1 Introduction

**W**hy all the mystery surrounding baluns? Here's some straight talk to dispel the rumors! The balun — to use, or not to use — is one of today's hottest topics in Amateur Radio. Because certain aspects of the connection between a coaxial feed line and a balanced antenna have been ignored, misunderstanding still exists concerning the function of baluns. Many commercial baluns embody some form of impedance transformer, promoting our tendency to misconstrue them as little more than a matching device, while their primary function is to provide proper current paths between balanced and unbalanced configurations.

To help clarify the misunderstanding, this chapter explains some of the undesirable effects that occur when a balun is not used, and some that occur when baluns employing coupling transformers are used. In many cases, these effects cause significant errors in measurements of antenna terminal impedance and SWR. This chapter also describes a simple and inexpensive method of loading the *outside* of a coaxial feed line with ferrite, which effectively produces a well-balanced, wide-band choke balun. Because this configuration eliminates the coupling transformer (with inherent impedance-transfer ratio errors), the accuracy obtainable

in antenna impedance and SWR measurements is greatly improved. In addition, antenna-matching networks may be used with this choke balun, because no mismatch limits are imposed by the balun.

### Sec 21.2 Transformer Accuracy

Using the General Radio 1606-A precision impedance bridge and the Boonton 250-A RX meter, I have made measurements of transformer-type baluns which prove that with a 50-ohm resistive load, the transformers in typical 1:1 or 4:1 baluns do not yield a true 1:1 or 4:1 impedance transfer ratio between their input and output terminals. This is because of losses, leakage reactance, and less than optimum coupling. My findings have been substantiated by the work of the late John Nagle, K4KJ (*Ref 80*). Furthermore, the impedance-transfer ratio of such baluns degrades even further when used with an antenna that is reactive from operation away from its resonant frequency. This degradation of impedance transfer associated with transformer-type baluns poses no serious operational problems. However, SWR curves plotted from measurements of an antenna using such a balun differ significantly from those using a choke balun that has no impedance-transfer error. Thus, when a precision bridge is used to measure antenna impedance ( $R + jX$ ), the data will be erroneous with either a transformer-type balun in the circuit, or

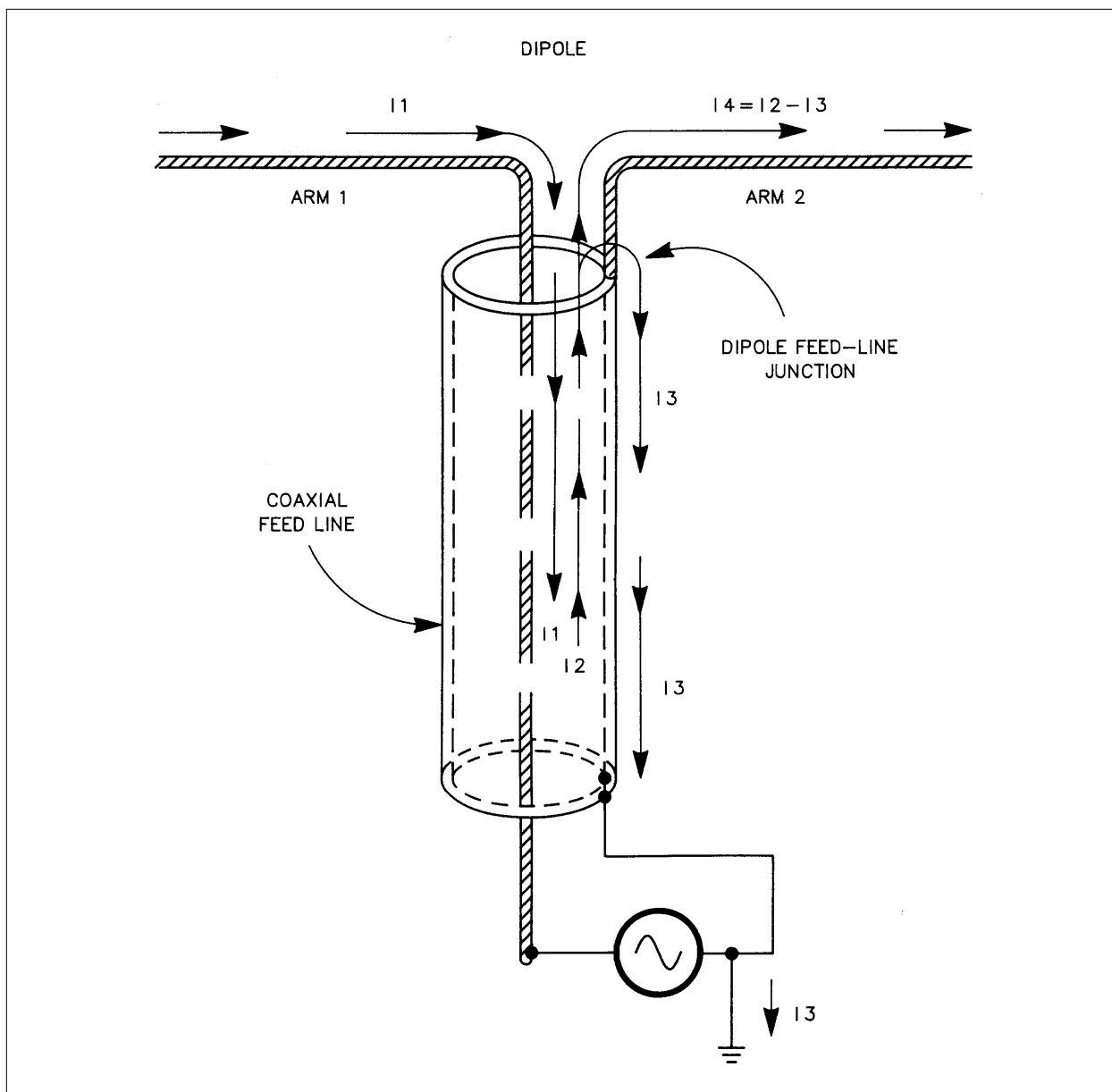

Fig 21-1—Illustration of the various current paths at a dipole feed point.

with no balun at all.

### Sec 21.3 Should SWR Change with Line Length?

We know that the feed-line input impedance changes with line length when the load (antenna) is not matched to the line. Sometimes trimming the length of the feed line helps to obtain a load impedance better suited to match the transmitter. Theoretically the SWR should not change with line length — except for a barely perceptible change because of the

corresponding change in line attenuation. Then why does the SWR sometimes change? If the SWR changes significantly with a change in line length, it means that the load impedance terminating the line is also changing. The load impedance can change with line length? Yes. If a balun is omitted when you feed a balanced antenna with coaxial cable, the load impedance will change when the line length is changed, and of course the SWR will also change! To explain this commonly experienced phenomenon we must investigate

how current flows in an antenna system.

To understand the functions of a balun, it is essential to be familiar with current paths at the feed point of the dipole. These paths are shown in Fig 21-1. Because of their symmetrical relationship, the dipole arms couple energy of equal magnitude and opposite phase onto the feed line, thus canceling induced current flow on the outside of the feed line (*Ref 81*). What is disturbing is the discovery that there are *three* paths for current flow in a coaxial feed line, instead of only two. How can there be three current paths in only two conductors? At RF, skin effect isolates the currents flowing on the inner and outer surfaces of the coaxial shield. This effect, which does not occur significantly at DC or low-frequency AC, prevents currents that flow on the inner braid surface from interacting with those on the outer surface, and vice versa.

As shown in Fig 21-1, while traveling within the transmission line, current I1 flows on the center conductor and I2 flows only on the inner surface of the outer shield. When antenna current is flowing from left to right as shown, I1 flows out of dipole arm 1, downward onto the center conductor, and returns to the generator. Current I2, being of opposite phase and direction, flows upward along the inside surface of the feed-line shield until it reaches the junction of dipole arm 2. At this junction, I2 divides into two separate paths to form I3 and I4. Current I3 flows back down the outside *surface* of the feed line, and I4, which equals I2 – I3, flows to the right onto dipole arm 2. The magnitude of I3 depends on the impedance to ground provided by the outside surface of the coaxial shield.

If the effective path length to RF ground is an odd multiple of  $\lambda/4$ , the impedance to ground will be very high, making I3 negligible. In this case, I1 and I4

will be nearly equal. On the other hand, if the RF path to ground is a multiple of  $\lambda/2$ , the impedance to ground will be fairly low, and current I3 may be substantial. This results in unequal currents in the dipole arms and radiation from the feed line. In many instances, this RF path to ground includes the transceiver line cord and some house wiring, terminating at the power-line ground! Thus, the amplitude of I3 varies with changes in feed-line length because of changes in the impedance between dipole arm 2 and ground.

Keep in mind that transmission-line currents I1 and I2 *cannot* produce radiation, because their fields are not only of equal magnitude and opposite phase, but their fields are also confined within the shield of the coaxial cable. However, the field developed by I3 *does radiate*, and thus, the outer surface of the coaxial braid effectively becomes dipole arm 3, which is connected in parallel with dipole arm 2.

To clarify this equivalent connection of radiators, I've simplified the circuit as shown in Fig 21-2. Since currents I1 and I2 do not interact with any other currents, we may hypothetically place the RF generator directly at the input terminals of the antenna. Now that the coaxial cable is no longer needed to transfer power from the generator to the antenna, the third conductor of the feed line (the outside surface) can be replaced with a single wire connected between arm 2 and RF ground. We have not changed the circuit electrically because I3, which previously flowed on the outside of the coaxial cable, still flows to ground — but now on the single wire shown.

We know that, depending on height, the impedance of a dipole at resonance is usually between 50 and 75 ohms, and is purely resistive. At frequencies above resonance, the resistance increases gradu-

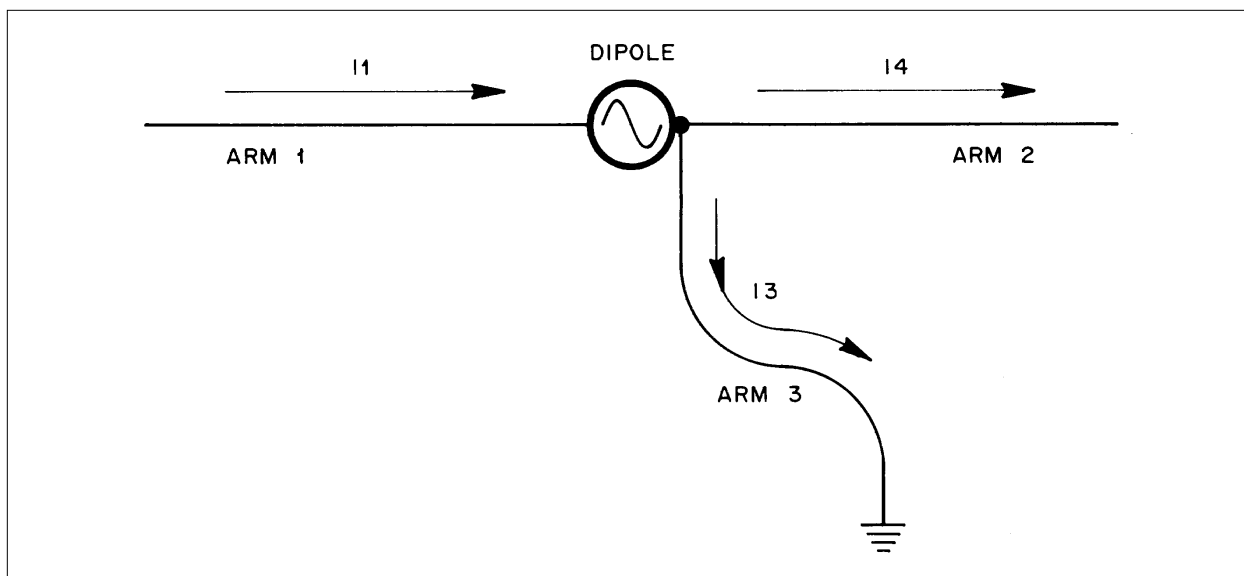

**Fig 21-2—Simplified electrical representation of Fig 21-1.**

ally, and series inductive reactance appears; below resonance, the resistance decreases and capacitive reactance appears. The impedance of each dipole arm is half of the total dipole impedance. Since the far end of arm 3 is at RF ground, its impedance behavior follows that of a short-circuited transmission line, with the short appearing at ground. Thus, when the length of arm 3 is an odd multiple of  $\lambda/4$ , its impedance is a parallel-resonant maximum, a high resistance typically from 2000 to 3000 ohms. This high resistance in parallel with arm 2 has little effect on the total dipole impedance. However, as the effective electrical length of arm 3 departs from  $\lambda/4$  (or odd multiples thereof), by changes in either its physical length or the generator frequency, the input resistance of arm 3 decreases, and reactance also appears in series with the resistance. This reactance is inductive when the length decreases and capacitive when the length increases. If the length of arm 3 is a multiple of  $\lambda/2$ , the resistance will be a series-resonant minimum value (but not zero, because of arm 3 radiation and ground loss). Thus, when arm 3 departs substantially from an odd multiple of  $\lambda/4$ , the net resistive and reactive

components of the parallel combination of arms 2 and 3 are different than those of arm 1. Consequently, the dipole impedance is different than if arm 3 was not present.

Returning to Fig 21-1, we can now see that, without a balun, changing the feed-line length also changes the antenna length (arm 3), which in turn affects the impedance at the input end of the feed line. Therefore, the SWR measured at the input of the transmission line does change with line length when no balun is present to eliminate I3. This phenomenon explains a point that is often puzzling for the amateur who uses no balun, and who believes that he must trim his dipole each time the feed-line length is changed “to keep the SWR down.”

It is evident that, in coupling an unbalanced line to a balanced load (such as a dipole), the *primary* function of a balun is to block the external current path between the inside and outside surfaces of the coaxial shield. With a balun in the circuit, I2 will not divide at the end of the feed line to form I3, but instead will flow only onto dipole arm 2. Thus, when I3 is zero, I4 equals I1, and the currents flowing on dipole arms 1 and 2 are equal and

therefore balanced.

After presenting all the above, let me stress that a balun at the antenna feed point will *not* prevent current from flowing on the outside of the coax shield when the coax is asymmetrically coupled to the antenna. Although I pointed out the above concept to Joe Reisert, W1JR, for use in his balun article (*Ref 82*), he apparently missed my point concerning the source of external current I3. Consequently, his Fig 2 and the associated paragraph do not address the *principal* function of a balun. Contrary to his explanation of his Fig 2, when antenna currents on the feed line are caused by *asymmetrical coupling* to the antenna, a balun *will not* eliminate these currents, but will only change their phase and magnitude.

### **Sec 21.4 The Effects of Using No Balun**

It should now be obvious that obtaining accurate impedance measurements of a dipole antenna is difficult. When a transformer-type balun is used to avoid errors caused by I3, impedance-transfer errors obscure the true impedance at the antenna terminals. If the balun is omitted, the true impedance is obscured by the impedance of arm 3 shunting half of the dipole. Since there is no practical way to determine the impedance of arm 3, the true antenna impedance and SWR cannot be calculated from the measured data (*Ref 83*).

Referring again to Fig 21-1, bear in mind that for any given physical length of feed line, the *electrical* length of the coaxial braid surface carrying I3 is not the same as that of the inside conductors carrying I1 and I2. This is because the dielectric constants and the propagation velocity factors are different for the internal dielectric material and the material of the outer jacket. For example, the ve-

locity factors for polyethylene and Teflon, the inner dielectric of various coaxial cables, are 0.659 and 0.695, respectively. The factor for foamed polyethylene is between 0.75 and 0.81, depending on the amount of air in the foamed material. If the outside surface of the coaxial cable is bare, the velocity factor for the outer shield carrying I3 approaches 0.95. However, the usually thin outer covering of polyvinylchloride (or sometimes Teflon) reduces the antenna-current velocity factor to a value somewhat less than 0.95.

From an operational viewpoint, current I3 itself is usually not detrimental to the performance of simple dipoles for *160 through 40 meters*. In addition, I3 alone does not cause TVI, unless the feed line is much closer to the TV antenna than the transmitting antenna. However, radiation from external feed-line current can cause severe distortion in the radiation patterns of directive antennas, such as Yagis and quads. Unless a gamma match or other type of unbalanced input-matching scheme is used, all beam antennas with balanced input terminals require a balun if the optimum performance of the antenna system is to be achieved when fed with coaxial cable. For example, when a balun is not employed, the feed line and tower together become a separate, non-directional vertical antenna. The tower then produces unwanted vertically-polarized radiation that fills in the rearward null in the beam pattern, destroying the front-to-back ratio. The tower radiates along with the feed line, because currents flowing on the outside surface of the line are induced in the tower through inductive and capacitive coupling between the feed line and the tower.

### **Sec 21.5 The Choke Balun**

Although many baluns embody some form of coupling transformer, an alterna-

tive is to insert an RF choke in the outer conductor of the feed line. This presents a high impedance to I3 without affecting the internal line currents. Advantages of this method are the lack of limitations on either maximum SWR or power handling. In addition, there is no impedance-transfer error that plagues transformer types of baluns (which causes a skewing of SWR and impedance plots), because the choke balun has no coupling transformer — the feed line goes straight through to the antenna terminals!

The simplest choke balun is formed by coiling up a few turns of the feed line, starting where it connects to the antenna terminals. In the frequency range of 14 to 30 MHz, several turns of feed line coiled in a 6- to 8-inch diameter form an inductor with enough series reactance to minimize I3 and practically eliminate feed-line radiation. Unfortunately, this form of choke (with its air core) is not practical below 14 MHz, because too much coiled-up feed line would be required to reduce I3 to an acceptable level at the lower frequencies.

A word of caution is in order when the choke balun is used on tower-mounted antennas: The choke coil should be placed directly at the feed terminals of the driven element. If the coil is placed away from the feed terminals, any portion of feed line between the terminals and the coil is coupled to the boom or mast, which in turn is coupled to one arm of the driven element. This unbalanced coupling results in an imbalance of currents in the driven element, causing pattern skewing and tower radiation.

The frequency range of the choke balun can be extended to well below 2.0 MHz by using a core of high-permeability ferrite instead of air. With higher core permeability, the choke inductance increases dramatically, thereby retaining

the high reactance needed to minimize I3 at the lower frequencies. Of great importance, no core saturation occurs at high power levels in the choke balun (a serious problem in transformer-type baluns), because the core excitation is low level, produced only by I3, and not by the high internal line current that feeds the antenna.

At my suggestion, Reisert made his choke balun with a Q1 material ( $\mu = 125$  to 400) ferrite toroid, winding 9 turns of RG-141 coaxial cable on the core for use from 14 to 30 MHz (*Ref 82*). However, although his 12-turn balun performs well at 14 MHz and above, it appears to provide only marginal performance at 4 MHz. The problem stems from the toroidal winding arrangement. It is difficult to get a sufficient number of turns of coaxial cable through the toroid, resulting in insufficient series inductance to block current I3.

## **Sec 21.6 The W2DU Balun — Constructed With Ferrite Beads**

I have obtained greatly improved choke-balun performance by placing several ferrite beads or sleeves of even higher permeability *around* the coaxial feed line (*Ref 84*). For readers who wish to build this simple coaxial balun, bead materials of various size and RF characteristics are available that dramatically increase both the resistance and reactance of a conductor. (Adding resistance to the reactance in this circuit improves the operational bandwidth of the balun with no increase in loss.) In general, the impedance of the outer coaxial braid surface increases almost proportionately with the number of beads placed over it. A combination of 50-ohm Teflon-dielectric RG-303 cable (or RG-141, with the fabric covering removed) and ferrite beads having an ID of 0.197

inches and a length of 0.190 inches form a superb, compact, wide-band balun. While the two inner conductors of the coaxial cable remain unaffected, the beads introduce a high impedance in series with the outer surface of the braid. This configuration effectively isolates the external output terminal of the feed line from that at the input end.

I made a test balun by slipping 300 no. 73 beads ( $\mu = 2500$  to 4000) over a piece of RG-303 coaxial cable. The impedance of the outer conductor of the cable measured  $4500 + j3800$  ohms at 4.0 MHz;  $15.6 + j13.1$  was measured using a single bead. For practical baluns to be used from 1.8 to 30 MHz (less than 12 inches long, including connector), use 50 no. 73 beads (Amidon no. FB-73-2401, or Certified Communications no. 73-W2DU.)<sup>1</sup> For 30 to 250 MHz, use 25 no. 43 beads ( $\mu = 950$  to 3000, Amidon no. FB-43-2401, or Certified Communications no. 43-W2DU). No. 64 beads ( $\mu = 250$  to 375) are recommended for use above 200 MHz, but I have not yet experimented with them. The coaxial cable need be only long enough to hold the beads and to access the end connectors. The plots appearing in the graph of Fig 21-3 show the measured values of series resistance  $R$ , reactance  $X$ , and impedance  $Z$  versus frequency of the outer braid surface of a choke balun for both the 25- and 50-bead types. With either balun,  $I_3$  will be negligible over the frequencies indicated.

At full legal input levels, no power-handling problems will arise using these baluns, because the CW power-handling capability of the cable is 3.5 kW at 50 MHz, and 9 kW at 10 MHz (*Ref 87*). Any

suitable connector that will mate with the load end of your feed line can be used at the input of the balun coax, and the balanced-output terminals may simply be pigtailed formed by the inner and outer conductors of the balun coax. Methods for connecting the output terminals of the balun to the antenna are left to your ingenuity.

To emphasize simplicity, what VHF antenna buff wouldn't delight in dumping his unwieldy, frequency-sensitive,  $\lambda/4$  line balun? You can replace it by simply putting some ferrite beads on the last few inches of the coaxial feed line!

## Sec 21.7 Analysis of Voltage and Current Baluns

Roy Lewallen, W7EL, has performed extensive analysis and testing of imbalance on different circuit arrangements of both the choke balun and the ferrite-core transformer balun (*Ref 118*). His analysis shows that, while choke baluns are *current* baluns, bifilar-wound 4:1 and trifilar-wound 1:1 transformer baluns are *voltage* baluns. To the best of my knowledge, with the exception of the W2DU ferrite-bead balun (which is a current balun), all 1:1 baluns available on the commercial market that use trifilar transformer baluns, are therefore *voltage* baluns.

Lewallen has determined analytically that current baluns *force* equal currents into opposite halves of a dipole, independent of the impedance of either half. On the other hand, voltage baluns provide only equal voltage to the opposite halves, and thus do not provide equal currents in each half if the impedances of the two halves are not identical. His tests show

<sup>1</sup> Ferrite bead material may be obtained from "The Wire Man", Press Jones, N8UG, Certified Communications, 261 Pittman Road, Landrum, SC 29356, 800-433-9473 and 800-727-9473, e-mail n8ug@juno.com, and n8ug@thewireman.com, www.thewireman.com. The Wire Man also has W2DU baluns available both in kit form and fully fabricated, ready for installation. Ferrite bead material is also available from Palomar Engineering, Box 462222, Escondido, CA, 92046, www.Palomar-Engineers.com, e-mail palomar@compuserve.com. Fully fabricated W2DU baluns are also manufactured by the Unadilla Antenna Manufacturing Company, PO Box 4215 BV, Andover, MA 01810 (508-475-7831), and are available at all Amateur Electronic Supply (AES) outlets. (NOTE: W2AU baluns made by Unadilla are *trifilar 1:1*, and *bifilar 4:1*, ferrite-core, transformer-type voltage baluns.)

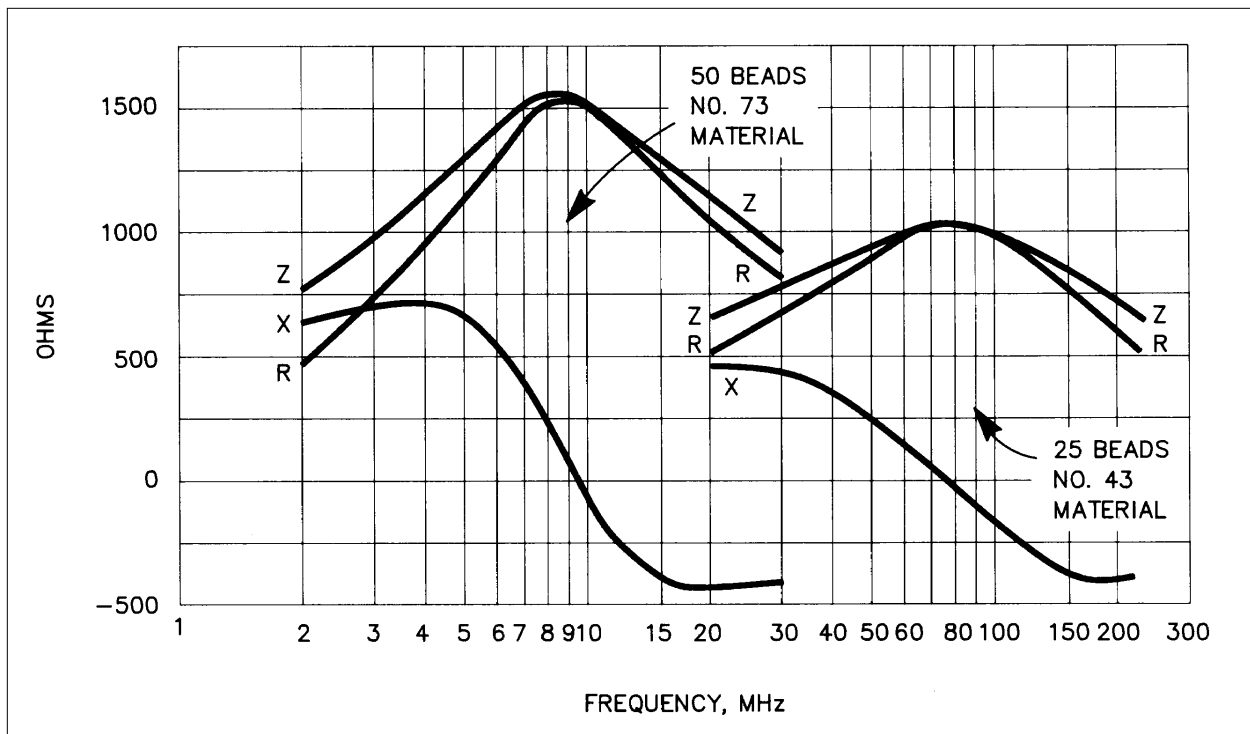

**Fig 21-3 — Graph of frequency versus series impedance of coaxial-balun shield outer surface.**

overwhelmingly that choke-type current baluns provide the best balance of the dipole currents, and the least flow of antenna current on the transmission line. Lewallen's paper is a real eye-opener concerning balun design and use. Tests performed by Dr John (Jack) Belrose, VE2CV, provide corroborating evidence of the validity of Lewallen's analysis and tests, which I describe in Sec 21.10.

In addition to Lewallen's work, Sabin also has performed a detailed analysis concerning the actions of the electric and magnetic fields in the operation of the 1:1 current balun, along with experimental evidence that prove his conclusions to be correct. (*Ref 136*)

### **Sec 21.8 Verifying Output-Current Balance In Current Baluns**

As stated, the ferrite-bead choke balun is a current balun. I use a simple test technique that proves the balun is a current balun, and which also determines

the degree of current balance between the balanced output terminals. As illustrated in Fig 21-4A, mount the balun on a one-foot square aluminum plate, with the shield side of the unbalanced coaxial input terminal grounded to the plate. Connect a separate resistor between each of the coaxial output terminals and the plate. Fig 21-4B shows the electrical equivalent of this test setup. With an RF voltage applied at the unbalanced input terminals, measure the voltage appearing across each resistor with an RF voltmeter. (I use a Hewlett-Packard 410B.) When both resistors are of the same value, identical values of voltage will appear across each resistor, indicating equal current in each resistor, and signifying a balanced output.

Although equal current flowing in equal resistances signifies a balanced output relative to voltage, it does not yet prove we have a current balun. However, we can prove we have a current balun if we can show that equal currents flow in



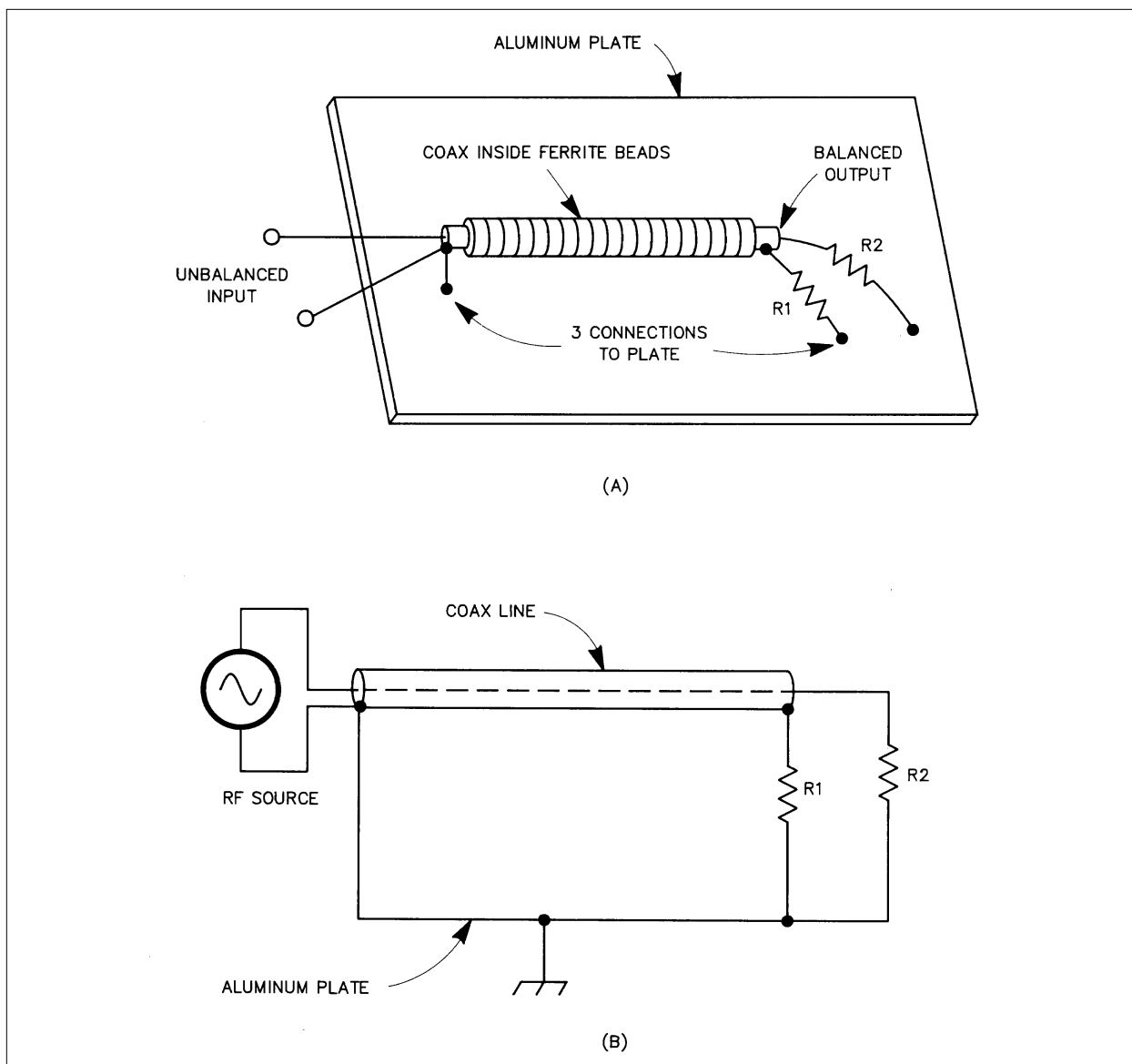

**Fig 21-4—The drawing at A shows a test setup for measuring the degree of balance in a current balun, and B shows its electrical equivalent, with an RF source. With a perfect balun and an RF voltage applied at the unbalanced input, the voltage drops across R1 and R2 will be directly proportional to their resistances. This proves that equal current flows in the two resistors, and no current flows on the outside of the coax shield to short out R1, contrary to the way it appears in B.**

each terminating resistor when their resistances are unequal. Indeed, this is the case, because with this balun the voltages appearing across *unequal* values of terminating resistances are directly proportional to the values of the resistance, while the currents are equal. For example, say the two terminating resistors are 50 and 100 ohms, and the input voltage is adjusted so that 1 volt appears across the

50-ohm resistor. Then 2 volts will appear across the 100-ohm resistor. Applying Ohm's Law now proves that equal currents are flowing in the two terminations, even though their impedances are different.

The ferrite beads perform their task of isolating the output and input terminals of the coaxial-line outer conductor by inserting a high longitudinal impedance

between them, which permits the balanced output from an unbalanced input. If you have any doubt about that, consider this: If the beads were not inserting a high resistance in series with the outer surface of the outer conductor, terminating resistor R1 in Fig 21-4 would be short circuited by the low resistance of the outer conductor and low resistance of the ground plane, thus the voltage appearing across R1 would be zero.

## Sec 21.9 Baluns With Antenna Tuners

In providing a balanced output for feeding open-wire or ladder-line transmission lines, it is common practice among manufacturers of antenna tuners to place the balun in the output circuit of the tuner. In all manufactured tuners with which I'm familiar, the baluns used are transformer-type, 4:1 voltage baluns wound around ferrite cores, usually toroids. Unfortunately, the output circuit is not necessarily the ideal place for the balun, for reasons I'll explain shortly. And further, the voltage balun is vastly inferior to the current balun in obtaining balanced currents in the feed line. Sec 21.10 explains why it is that when you use balanced feeders, the ideal arrangement for an antenna tuner is to place the balun at the *input* of the tuner, and for the balun to be a choke-type *current* balun such as the W2DU balun.

Let's first examine some of the problems encountered when you use a ferrite-core, transformer-type voltage balun in the output circuit of the tuner. When a transformer balun has a ferrite core, the core is subjected to the total magnetic flux developed by the load current, and the resulting high magnetic flux density can cause the core to saturate. When the core saturates, the RF waveform in the output becomes distorted, creating undesir-

able harmonic signals. A transformerless choke balun made with coiled-up coax, or a short coax with external ferrite beads, has no core to saturate. And in addition, the external beads are not subjected to the magnetic flux developed by the load current. The beads are subjected only to the flux developed by the small current flowing through the high impedance that the beads create on the outside surface of the outer conductor. Hence, no harmonics are generated with the ferrite-bead current balun.

Another problem encountered with the ferrite-core transformer-type voltage balun is the distributed capacitance between its windings, which causes current unbalance between the two output ports that feed the balanced feed line. The input impedance of a balanced feed line can range in value from low to very high, and generally has a reactance component. The higher the line-input impedance, and the higher the operating frequency, the greater is the effect of the distributed capacitance in contributing to output current unbalance. On the other hand, output current unbalance is negligible with the ferrite-bead current balun.

Another undesirable feature of the 4:1 ferrite-core balun placed at the output of the tuner is that it can easily be permanently damaged. This can happen from overloading the balun when you operate with high power into a line having a high SWR that results in a high input impedance containing a large amount of reactance.

A still further undesirable feature of the 4:1 ferrite-core balun is its contribution to power loss. Typical losses with this type of balun range from around 0.5 dB at 2 MHz to 2 dB at 30 MHz. In contrast, the loss in the W2DU balun is minimal, only from 0.1 to 0.2 dB across the band, because the only loss involved is in the

attenuation suffered in a 10.5-inch length of coaxial line.

### **Sec 21.10 Placing the Balun at the Input of the Antenna Tuner**

At least three writers have published articles that advocate placing the balun at the *input* of the tuner, rather than at the output, for the same reasons I explained above. Consequently, it is for these reasons it's possible that this will be the way antenna tuners will be built in the future. These writers are John Belrose, VE2CV (*Ref 132*), Albert Roehm, W2OBJ (*Ref 127*), and Richard Measures, AG6K (*Ref 133*). Belrose (in 1981) showed a balanced T network driven by a 4:1 voltage balun (but see the paragraphs that follow). Measures uses a balanced L network fed by a 1:1 choke, or current balun comprising a coiled-up section of coaxial line. To cover the range of 1.8 to 30 MHz, his balun is a rather bulky 20 feet of coax coiled on a 5-inch diameter ABS pipe. The bulkiness can be reduced by using the W2DU configuration — a 10.5-inch long coax section covered with external ferrite beads, which is just what Roehm did in his arrangement. However, the results of Roehm's and Measures' placing the balun at the input of the tuner are excellent.

Let me add a few words about the work of John (Jack) Belrose, Ph.D, Cantab, VE2CV (*Ref 132*). Jack is an ARRL Technical Advisor (TA), and is well known in Amateur Radio for his expertise in antennas. He has for some time been the Director of the Radio Communications Lab, Department of Communications, of the Canadian Government. Jack has recently conducted tests on a novel approach to the broadbanding of dipole antennas, and is publishing the results in *QST* (*Ref 134*). His antenna is asymmetrical with respect to the impedance

seen relative to each wire of a balanced feed line. Consequently, he discovered that the currents in each wire of the feed line were severely unbalanced when using the 4:1 voltage balun to feed the balanced antenna tuner. He then substituted a commercially manufactured W2DU current balun and repeated the measurements. To his surprise, the feed-line currents were almost perfectly balanced when using the W2DU balun. Jack's feed line comprised two parallel coaxial lines; the outer conductors were connected together and grounded to the tuner, and the center conductors were used as the balanced feeders.

Jack's measurements also revealed that when he used the voltage balun, the current on the outer conductors was high, and varied widely over the frequency range from 2 to 30 MHz, also signifying poor balance. However, when using the W2DU current balun, the outer conductor current was very low, and nearly constant, verifying the good balance. These results of Jack's measurements are exciting for me, because they offer additional verification of my own measurements that prove the W2DU current balun solves many of the problems experienced with transformer baluns that I described earlier.

Jack has prepared graphs that compare input impedance and attenuation versus frequency of a ferrite-core balun and the W2DU balun. The data in the graphs again confirm my measurements. They attest to the remarkable superiority of using ferrite beads around a coaxial line to form a current balun, compared to the ferrite-core transformer-type voltage balun. Jack has also devised a unique method of forming a 4:1 current balun by using two W2DU baluns, connecting them in parallel at the input and in series at the output.

Since the first edition of this book was published, Roy Lewallen performed an analysis concerning balun operation with antenna tuners, comparing the performance of 1:1 baluns placed at either end

of the tuner. In private correspondence, he reported that there is an insignificant difference in performance of the balun, whether placed at the input or the output of the tuner.